



Micro-STAT[®]

ELECTRONIC HUMIDISTAT: H200

- ONE OR TWO STAGES



DESCRIPTION

The H200 series low voltage, microcomputer-based PI (proportional and integral) humidistats are designed for accurate humidification and/or dehumidification control in non-corrosive commercial applications such as: hospitals, schools, office buildings, retail stores, museums, computer rooms, etc.

The H200 series is available with one or two outputs for maximum flexibility. Outputs can be of the following type: proportional, on/off, and pulse width modulation (PWM). In addition, a wide variety of mounting configurations is available. Sensing options include remote duct and room as well as integral room and duct.

Setpoint adjustment can be either concealed or exposed, adding even more versatility to the product. Exposed models feature internally selectable minimum and maximum setpoint knob stops.

In order to facilitate periodic recalibration, the H200 series contains a unique autocal key, which permits instant recalibration (see dimension drawing on page 5 for location).

Each humidistat is computer calibrated and factory programmed with default parameters. All control parameters (such as proportional band, stage differential, etc.) may be changed in the field with the H263 programming tool without having to remove the thermostat cover. The H263 also doubles as a diagnostic tool and indicates the status of all the inputs and outputs, and will reduce troubleshooting time by quickly identifying the specific problem.



Fig. 1: Wall mounted humidistat

Features	Benefits
• Microcomputer-based design with PI algorithm	⇒ Exceptional accuracy
• One or two outputs	⇒ Controls humidification and dehumidification equipment
• On/off and/or proportional outputs	⇒ Greater flexibility
• Direct or reverse acting outputs	⇒ Controls humidification and dehumidification equipment
• Integrated and remote sensing	⇒ Larger choice of mounting options
• Autocal button	⇒ Permits instant recalibration
• Concealed or exposed set point	⇒ Can be used in a large variety of environments
• Output signal to digital indicating devices	⇒ Increases functionality of product
• Optional H263 diagnostic tool with digital display	⇒ Simplifies troubleshooting
• Sensor failure protection	⇒ Prevent water damage
• CE approved	⇒ Can be sold in European markets

TABLE 1: ORDER CODE

H200 - **A-B** - **C-D** - **E-F**

A Output no. 1 (controlled device)	
1	ON/OFF (15 min. time base)
4	(PWM) 24 VAC
5	(PWM) 5 VDC
6	Analog 0-10 VDC

B Output no. 2 (controlled device)	
0	Not installed
1	ON/OFF (15 min. time based)
4	(PWM) 24 Volts AC
5	(PWM) 5 Volts DC
6	Analog 0-10 Volts DC
8	Signal transmitter 0-10 VDC (1V= 10% , 9V=90%)
9	Signal transmitter 0-5 VDC (0.5V= 10% ; 4.5 V=90%)

C Output no. 1 and 2 control mode	
1	Humidify
2	Dehumidify
3	Humidify (no. 1) and dehumidify (no. 2)
4	Dehumidify (no. 1) and humidify (no. 2)

D Main sensor location	Sensor	
0	Not installed	None
1	Inside humidistat (Local)	H50
2	Duct mount (stat on duct)	H60
3	Duct mount (stat on wall)	H71
4	Remote wall mount	H80

E Setpoint adjustment	
1	User adjustable
2	Blind cover

F Future option	
0	Unused

Example: H200 - 61 - 32 - 10

One "SCR" 0 to 10 volts humidify output and one relay dehumidify output.

Humidistat and sensor are duct mount. Setpoint is user adjustable.

◆ Resolution: 0.5 % for retransmit only

■ See sensor specifications for dimensions of sensors

Note: the complete order code includes the sensor that will be shipped with the humidistat.

WIRING

2 ON/OFF OUTPUTS

Single transformer

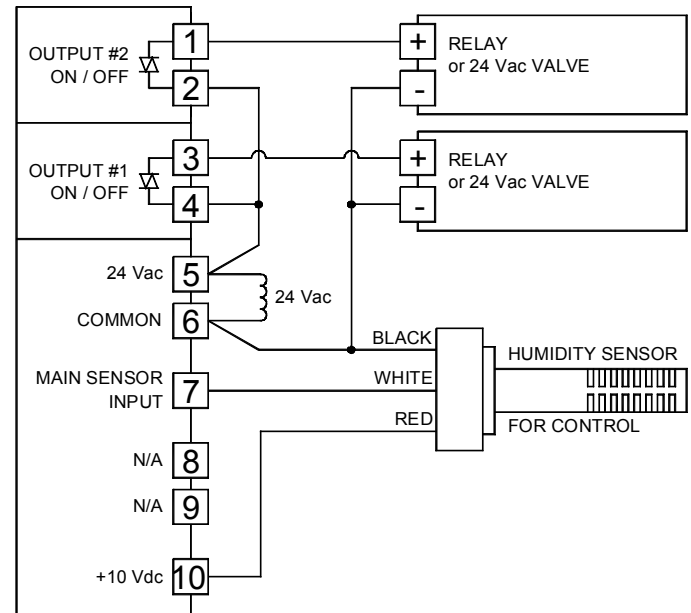

Fig.2: Wiring diagram with single transformer

Multiple transformers

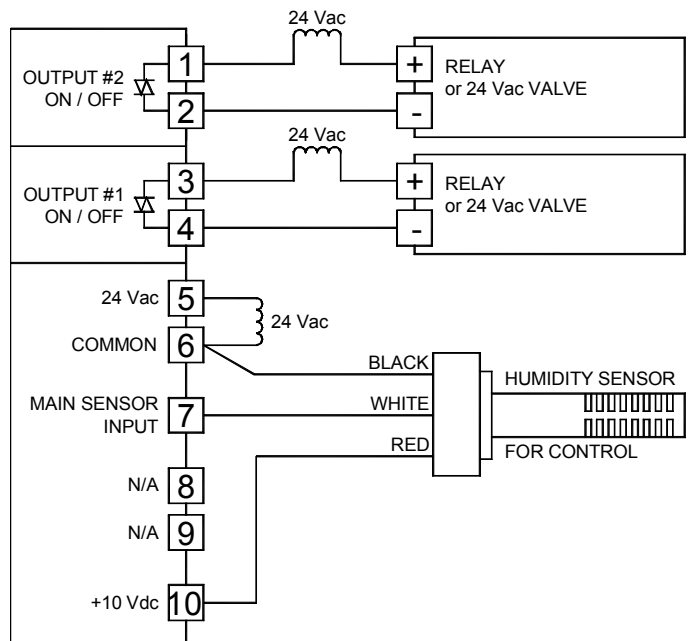

Fig.3: Wiring diagram with multiple transformers

Note: Both of the above wiring diagrams show how to wire output of type 1, 2, 3 and 4 (switched 24 Vac). For outputs of type 5 and 6 (Vdc out) refer to Fig.4 and Fig.5 on next page.

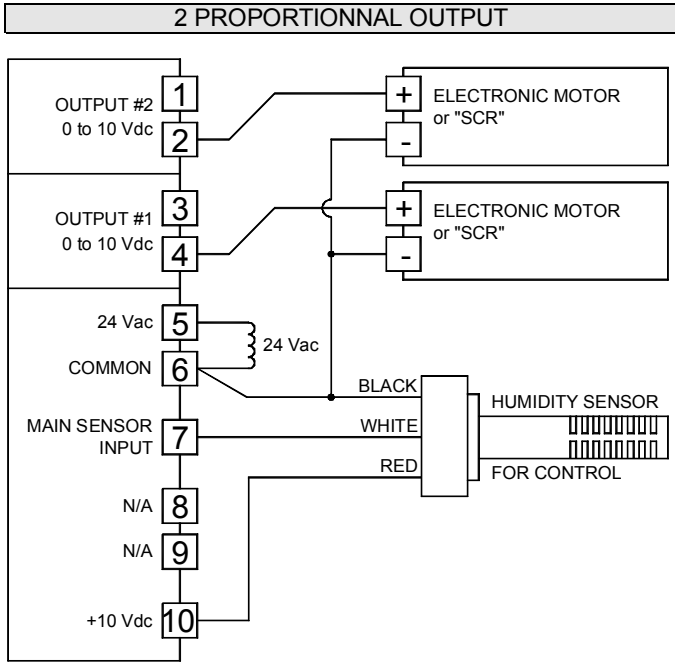

Fig. 4: Wiring diagram with two analog outputs

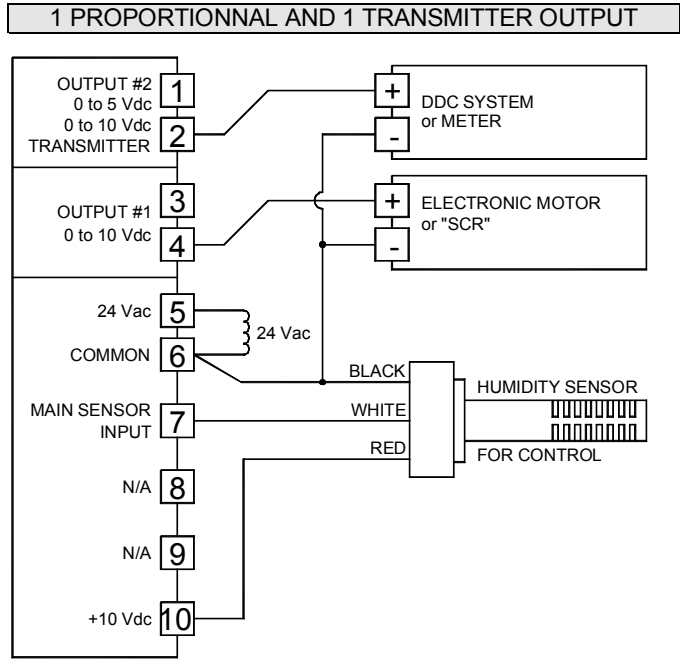

Fig. 5: Wiring diagram with one analog and one transmitter output

APPLICATION EXAMPLE:

Steam humidification system controlled by a 0 to 10 Vdc valve wired to output #1. Remote humidity display using 0 to 5 Vdc signal is wired to output #2. The humidity sensor is located in the return air duct.

Humidistat model number: **H200-69-13-10**

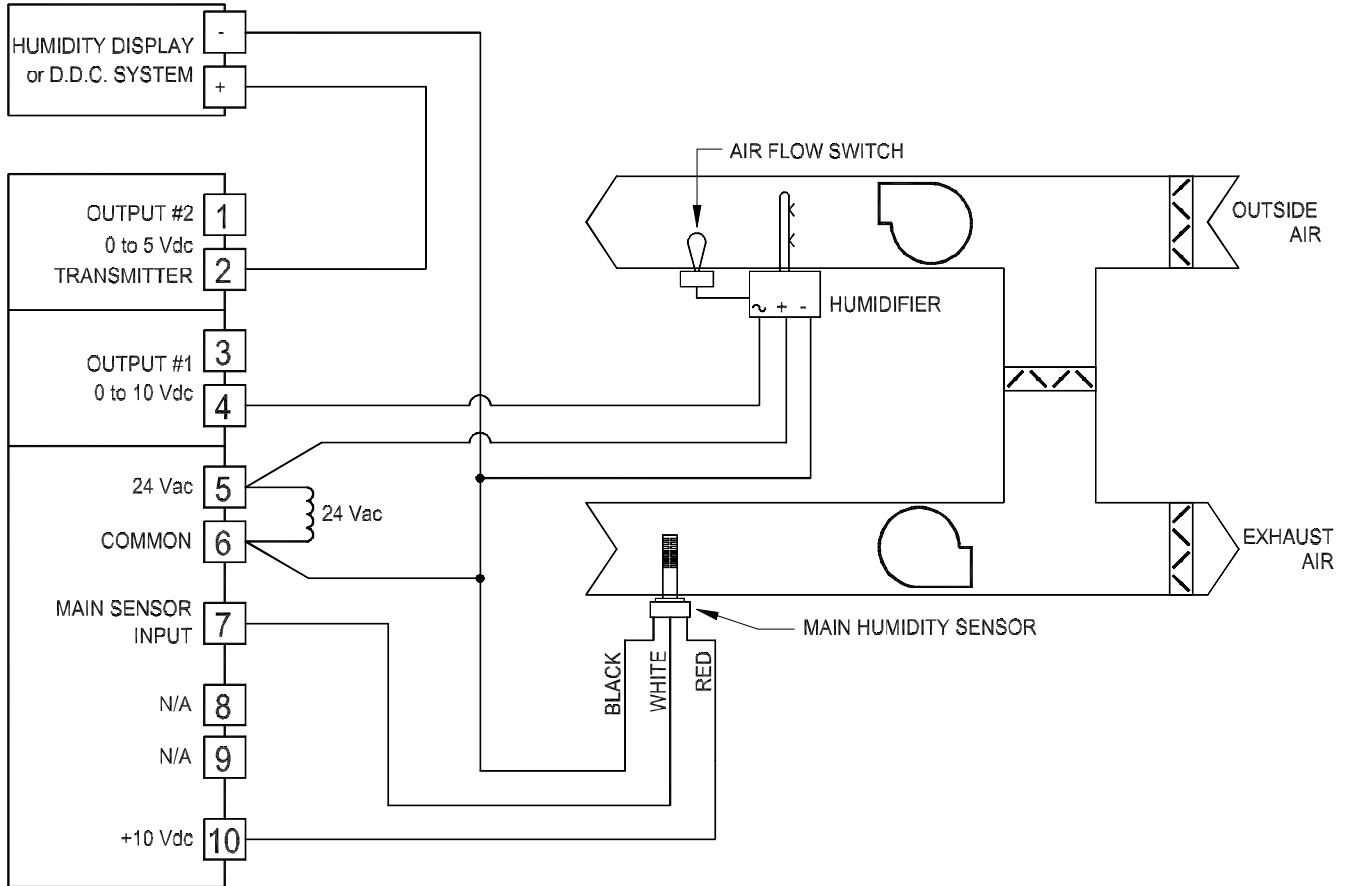

Fig. 6: Application example

TABLE 2: HUMIDISTAT ACCESSORIES

H50	Internal humidity sensor for H200 humidistat and for H80 remote wall sensor.
H60	Duct humidity sensor to mount directly onto the back of any H200 humidistat.
H71	Duct humidity sensor to mount directly onto the supply or return of the ventilation duct.
H80	Wall humidity sensor to mount in any remote location.
H263	Programming tool for troubleshooting, viewing and modifying humidistat parameters.
008-0089	Replacement lexan (cover sticker) for H200 humidistat.
024-0048	Humidistat replacement base with connector (H50 internal humidity sensor not included).

H50 INTERNAL SENSOR



This humidity sensor can be mounted directly on 024-0048 humidistat base.

H60 DUCT SENSOR



This humidity sensor can be mounted directly onto the back of any H200 humidistat, with the supplied hardware. This transforms the humidistat into a duct-mounted humidistat.

H71 REMOTE DUCT SENSOR



This humidity sensor can be mounted directly onto the supply or return of the ventilation duct. The H200 may be located on the wall with humidity sensing from the remote H71 sensor location.

H80 REMOTE WALL SENSOR



This humidity sensor can be wall mounted in any remote location. The humidistat may be located on the duct or other location, with humidity sensing from the H80 sensor location.

H263 PROGRAMMING TOOL



This tool is used to change humidistat parameters. It is also useful for troubleshooting. Just plug it in the humidistat through the casing. See page 6 for more details.



WARNING:

All H200 humidistats are intended to control equipment under normal operating conditions. Where failure or malfunction of H200 series humidistats could lead to an abnormal operating condition that could cause personal injury or damage to the equipment or other property, other devices (limit or safety controls) or systems (alarm or supervisory) intended to warn of, or protect against, failure or malfunction of H200 humidistats must be incorporated into and maintained as part of the control system.

CONTROL SCHEMATIC:

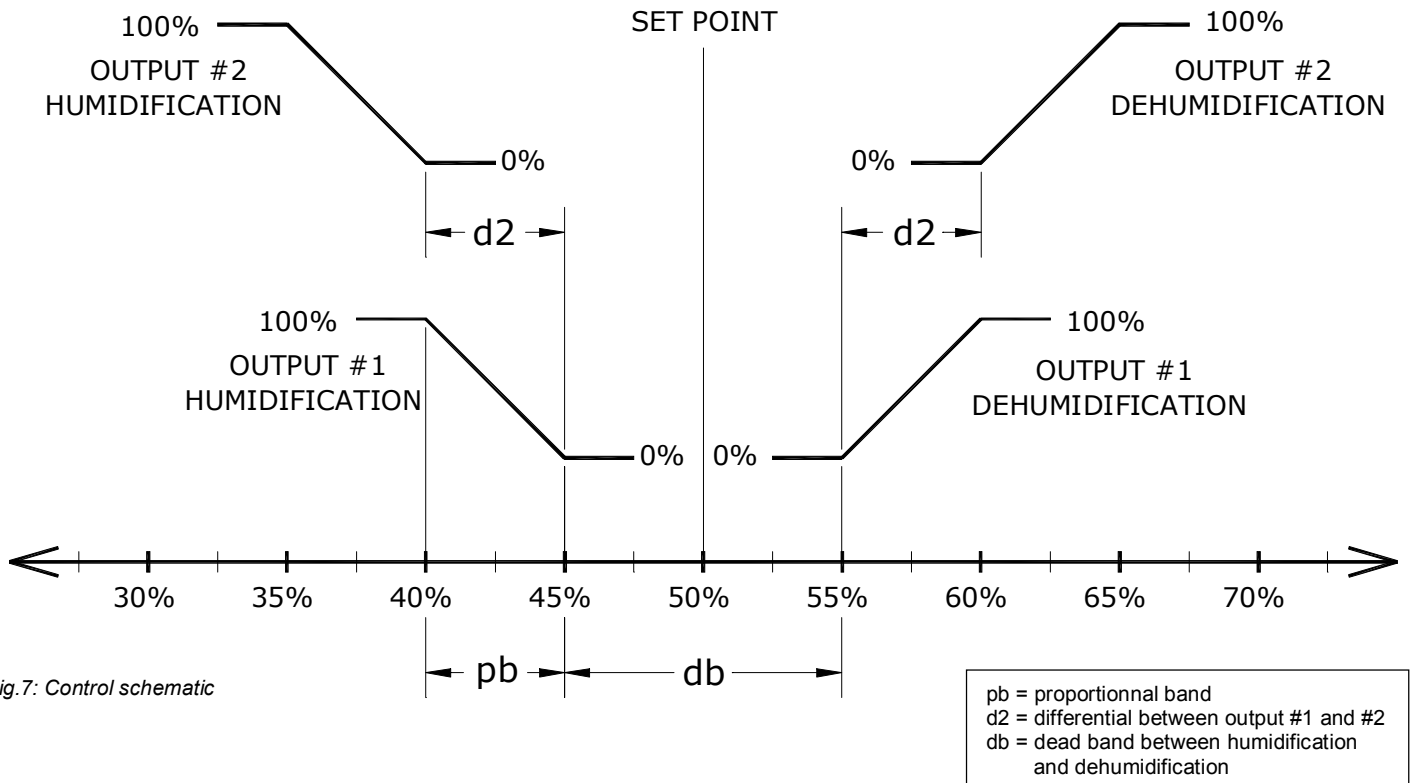

TABLE 3: H200 PARAMETERS

CODE	VALUES	DEFAULT VALUE	DESCRIPTION
Db	0 to 40 % R.H.	25% R.H.	Dead Band between humidification and dehumidification.
SL	30 to 100 % R.H.	85% R.H.	Supply Limitation: High humidity limit in the supply duct (H270 only)
d2	0 to 199 % (of proportional band)	100%	Differential for output #2": Shift for output 2 relative to output 1
Pb	0 = 1.6 % R.H. 1 = 3.2 % R.H. 2 = 6.4 % R.H. 3 = 12.8 % R.H. 4 = 25.6 % R.H.	2= 6.4% R.H.	Proportional Band
o1	0 = Humidification 1 = Dehumidification		"Output #1" Action for output no 1
o2	0 = Humidification 1 = Dehumidification		"Output #2" Action for output no 2
cc	2 = Without integral 3 = With integral	3	"Control Code"
t1	0 = On/off 1 = 8 minutes 2 = 1 second		"Time #1" Time period for output no 1
t2	0 = On/off 1 = 8 minutes 2 = 1 second		"Time #2" Time period for output no. 2
rA	0 = °C 1 = °F	1 DO NOT CHANGE	"Range" Temperature Scale
Ca	± 13 %		Calibration (deviation mode: <u>DO NOT MODIFY: USE AUTOCAL PROCEDURE; FOR H100 TRANSMITTER, USE THE ZERO POTENTIOMETER ON THE TRANSMITTER.</u>
hA	0 à 127		"Hardware assembly" Code related to thermostat model and entered at initial setup at the factory.
it	1 to 99 = 1 TO 99 MINUTES	60	"Integral time" Error integration time.
Lt	-40 à +40 °C (-40 à 105 °F)	-20 °F	"Lower temperature" minimum outside temperature for setpoint reset (model H270 only)
Ht	-40 à +40 °C (-40 à 105 °F)	32 °F	"Higher temperature" maximum outside temperature for setpoint reset (model H270 only)
rE	1 à 99 % R.H.	20 % R.H.	"Reset" Minimum humidity value (% HR) (model H270 only) Example: rE = 20%. Humidity setpoint will be reset from selected setpoint to 20%, from Ht to Lt

AUTOCAL PROCEDURE

1. Measure the room humidity near the Viconics humidistat with an accurate hygrometer.
2. Turn the humidistat set point dial to match the reading of the hygrometer.
3. Push and hold the autocal button for few seconds or until the internal red light turns on. Look through the slots on the left side of the humidistat.

SENSOR FAILURE PROTECTION

The sensor is the most sensitive part of the humidistat and also the most exposed. In the case of a sensor failure in humidification mode, the H200 will automatically assume a failsafe output of 0%.

SPECIFICATIONS

Operating Conditions: 5 °C to 50 °C (32 °F to 122 °F)
 •Control: 0% to 95% R.H. non-condensing
 •Sensor: 0% to 100% R.H. (see Note 1.)

Resolution: ± 0.1 %
 Repeatability: 0.5 %

Accuracy and sensor interchangeability:
 ± 2 % R.H. from 0 to 100 % R.H.

Range: 10 % to 90 % R.H. for 5 to 50 °C
 (41 °F to 122 °F)

Temperature effect: 0.05 % / °F

Outputs: Isolated Triac: 30 Vac at ½ A max.*
 0 to 5 VDC into 1KΩ resistance min.
 0 to 10 VDC into 2KΩ resistance min.
 0/5 VDC at 20 mA max.for both outputs

Power: 24 VAC -15%, +10%; 50/60 Hz; 2 VA

Base & casing: Off-white; self extinguishing
 ABS plastic

*Triac outputs can only switch AC loads. Use relays when switching dc loads.

Note 1. Humidity sensor: Solid state humidity sensor. Suitable for normal, clean air. Not to be used in corrosive or harmful environment.

DIMENSIONS

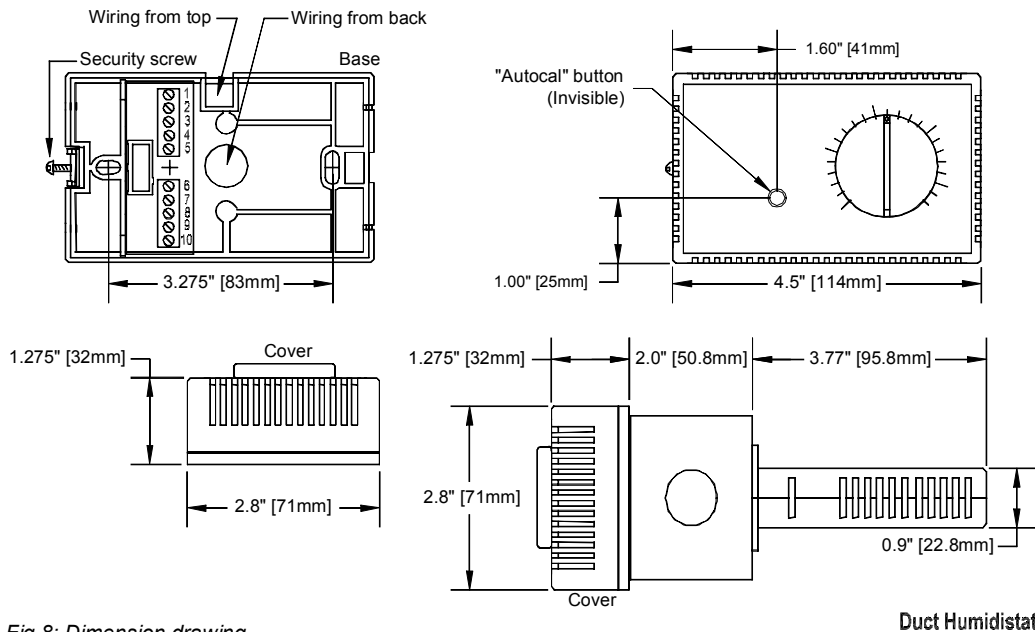

Fig.8: Dimension drawing

Note: Specifications and equipment are subject to change without prior notice.

TABLE 4: SENSOR CHARACTERISTICS

Voltage between black and white wire, terminals #6 and #7

HUMIDITY	SENSOR OUTPUT
0 %	1.05 V
5 %	1.19 V
10 %	1.34 V
15 %	1.48 V
20 %	1.63 V
25 %	1.77 V
30 %	1.92 V
35 %	2.06 V
40 %	2.20 V
45 %	2.35 V
50 %	2.49 V
55 %	2.64 V
60 %	2.78 V
65 %	2.93 V
70 %	3.07 V
75 %	3.21 V
80 %	3.36 V
85 %	3.50 V
90 %	3.65 V
95 %	3.79 V
100 %	3.94 V